

MODELL
ECU

90 Grad
EINSCHRAUBBOHRUNG: T-11A

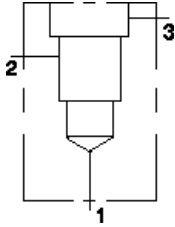

KONFIGURATION ÄNDERN

(none) Modifier 6061-T651
Aluminum, Buna-N

PORT HEADINGS AND SIZES

Model	Port Heading	Size
ECU	Ports 1 & 2	3/8" BSPP
ECU	Port 3	1/4" BSPP

BEMERKUNGEN

Important: Carefully consider the maximum system pressure. The pressure rating of the manifold is dependent on the manifold material, with the port type/size a secondary consideration. Manifolds constructed of aluminum are not rated for pressures higher than 3000 psi (210 bar), regardless of the port type/size specified.

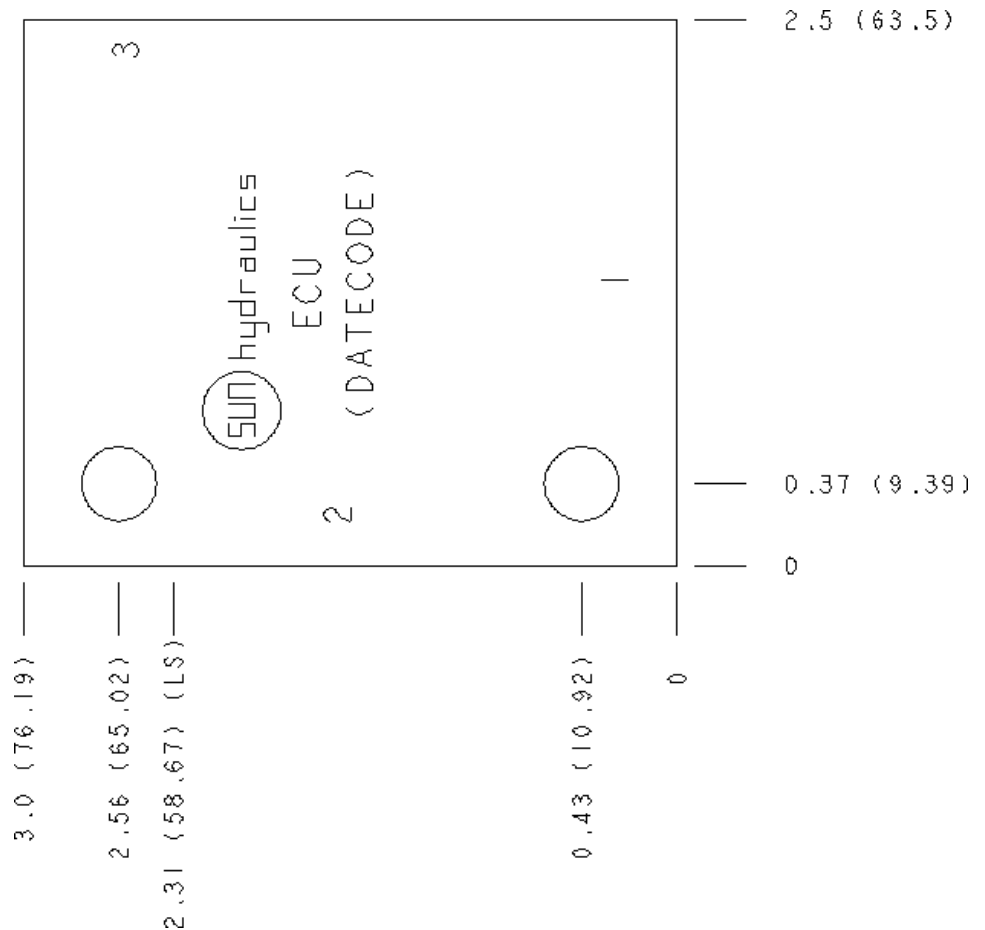

TECHNISCHE DATEN

Gehäusotyp	Rohrleitungseinbau
Lochbild	Kein
Gehäuseeigenschaften	90 Grad
Montagebohrungsdurchmesser	8.6 mm
Montagebohrungstiefe	durchgehend
Anzahl der Montagebohrungen	2
Einschraubbohrung	T-11A
Open Cavities	1
Anschlussgröße	G 3/8"

CONFIGURATION OPTIONS

MODIFIER

Standard Options

6061-T651 Aluminum, Buna-N

MANIFOLD FACES

FACE GRID

1	2	3	4
5	6	7	8
9	10	11	12

Face 2

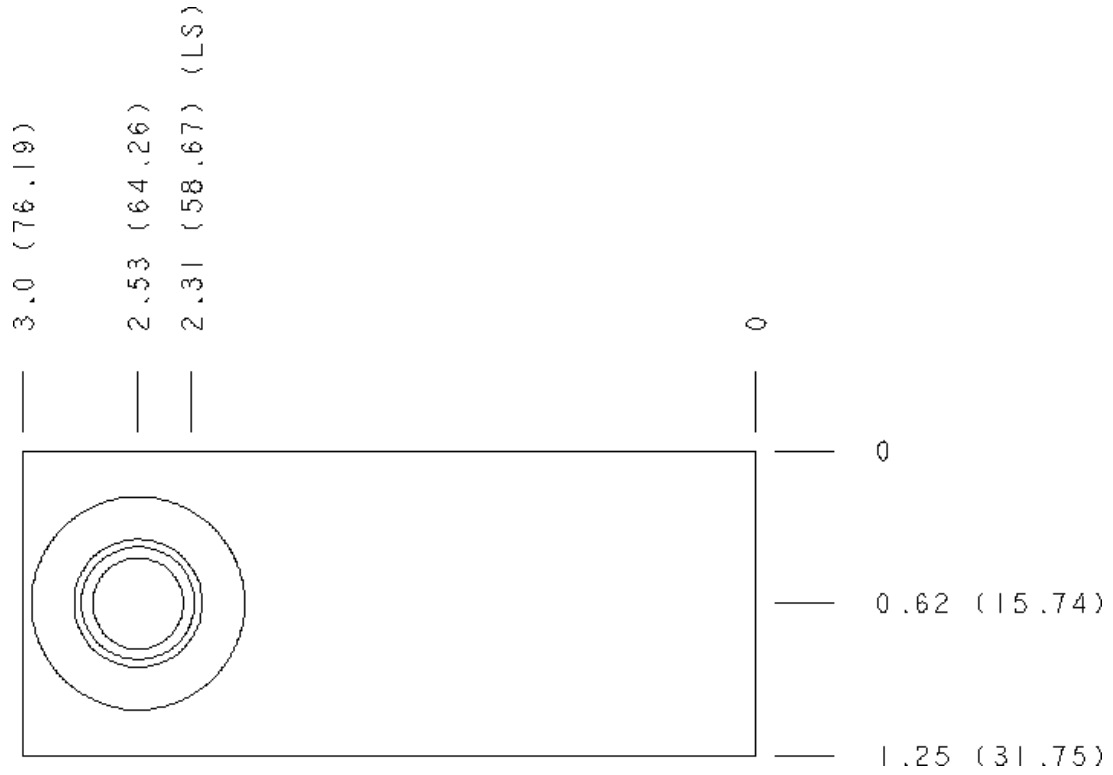

Face 5

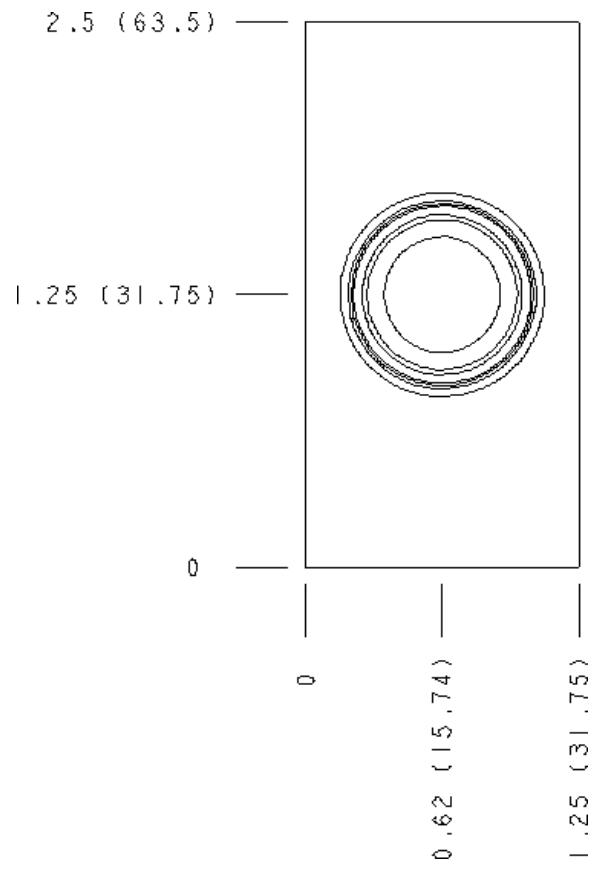

Face 6

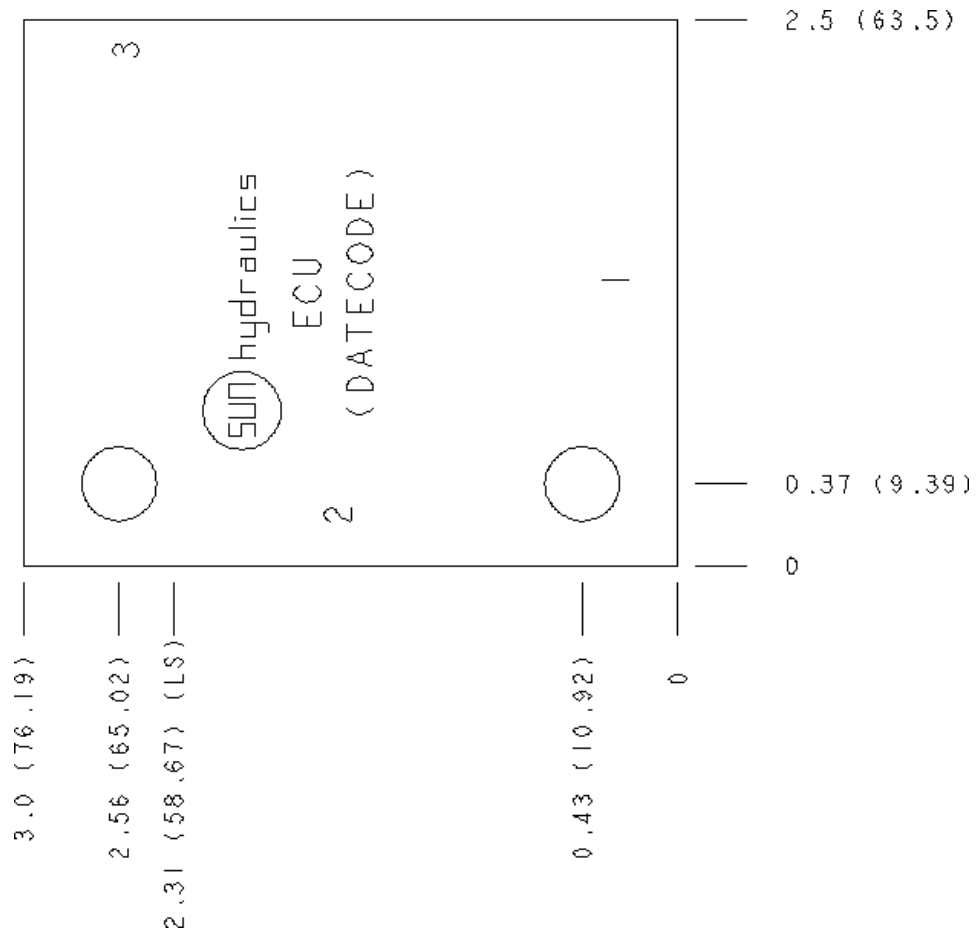

Face 7

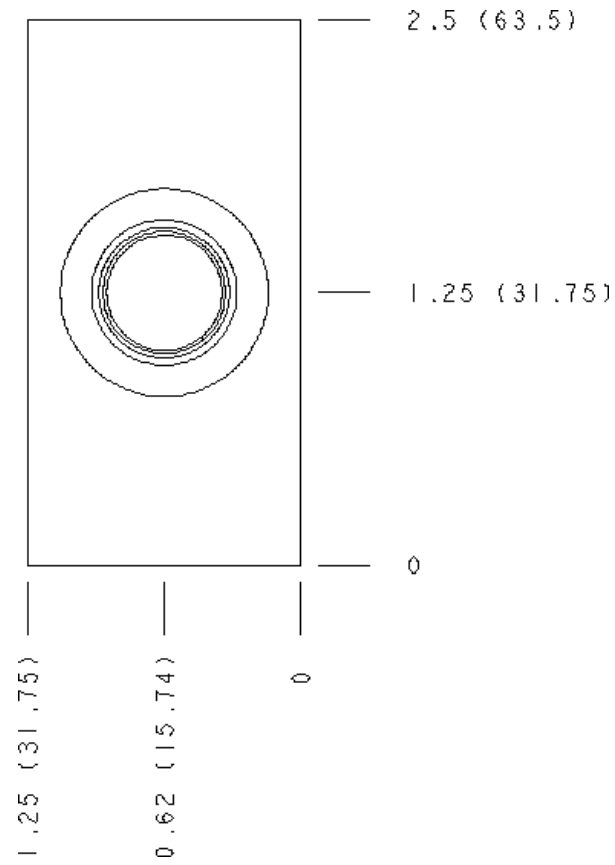

Face 10

