

MODELL
DBT

Aus T
EINSCHRAUBBOHRUNG: T-5A

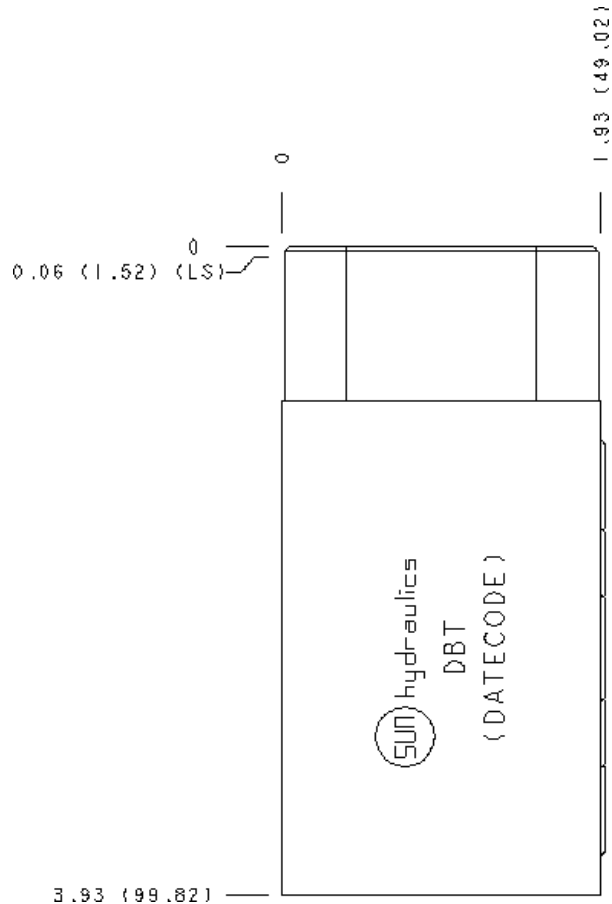
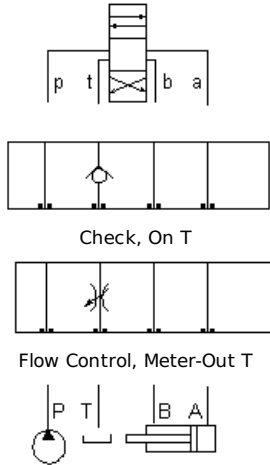

KONFIGURATION ÄNDERN

(none) Modifier 6061-T651
Aluminum, Buna-N

KOMPONENTEN

Part	Beschreibung	Anzahl
500-001-014	O-Ring	5

BEMERKUNGEN

For check valve application, use only with CX*A check valves - free flow nose to side.

Important: Carefully consider the maximum system pressure. The pressure rating of the manifold is dependent on the manifold material, with the port type/size a secondary consideration. Manifolds constructed of aluminum are not rated for pressures higher than 3000 psi (210 bar), regardless of the port type/size specified.

TECHNISCHE DATEN

Gehäusotyp	Sandwich
Lochbild	ISO 05
Gehäuseeigenschaften	Aus T
Verkettungshöhe	49 mm
Einschraubbohrung	T-5A
Open Cavities	1

SYMBOLS

Check, On T

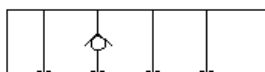

Flow Control, Meter-Out T

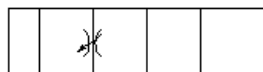

CONFIGURATION OPTIONS

MODIFIER

		6061-T651 Aluminum, Buna-N
Standard Options	/S	65-45-12 Ductile Iron, Buna-N, Blackened
	/V	6061-T651 Aluminum, Viton
	/Y	65-45-12 Ductile Iron, Viton, Blackened

MANIFOLD FACES

FACE GRID

1	2	3	4
5	6	7	8
9	10	11	12

Face 2

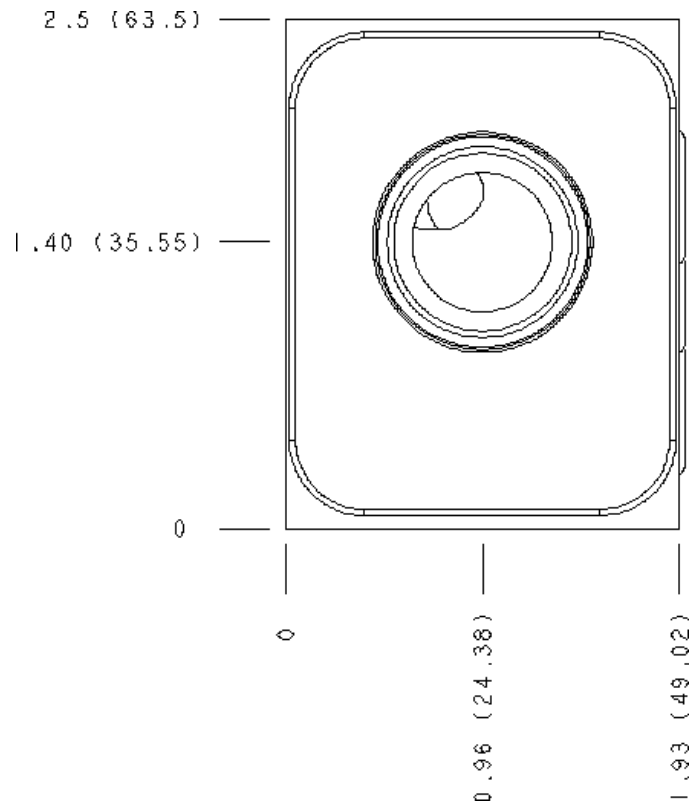

Face 5

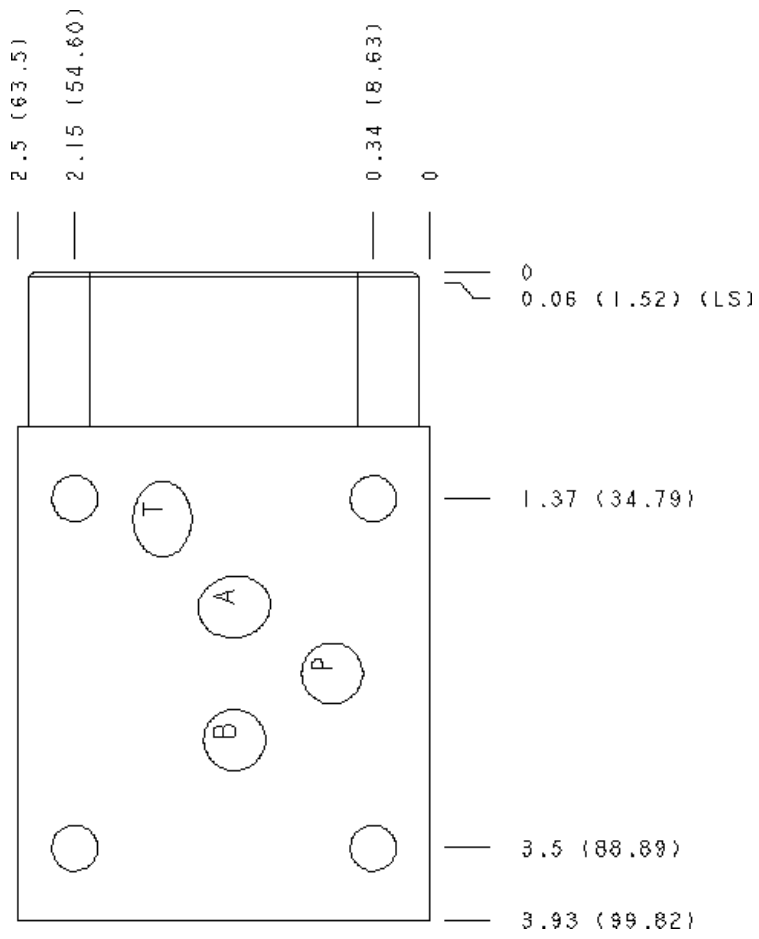

Face 6

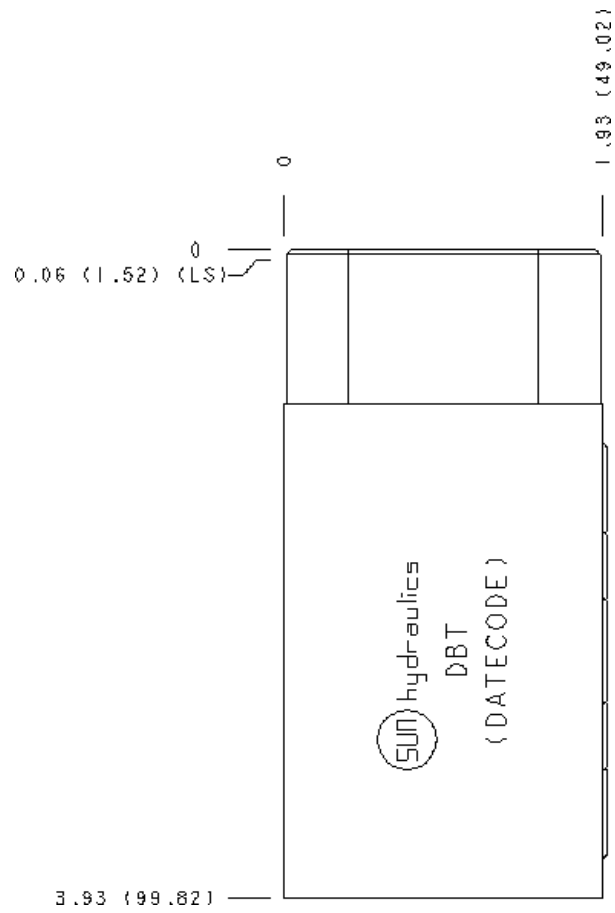

Face 7

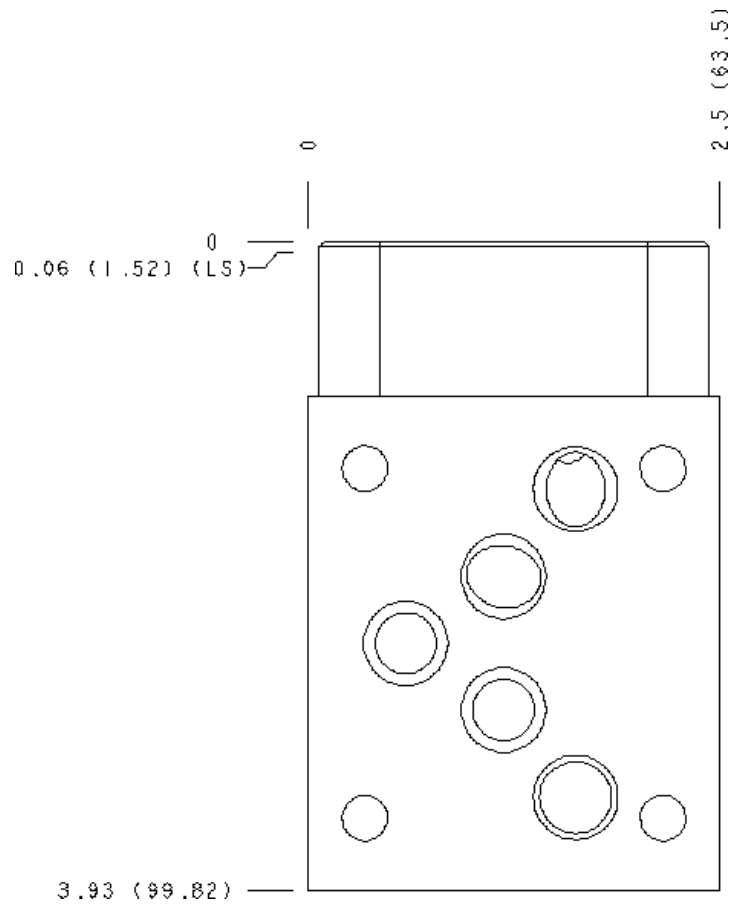

Face 8

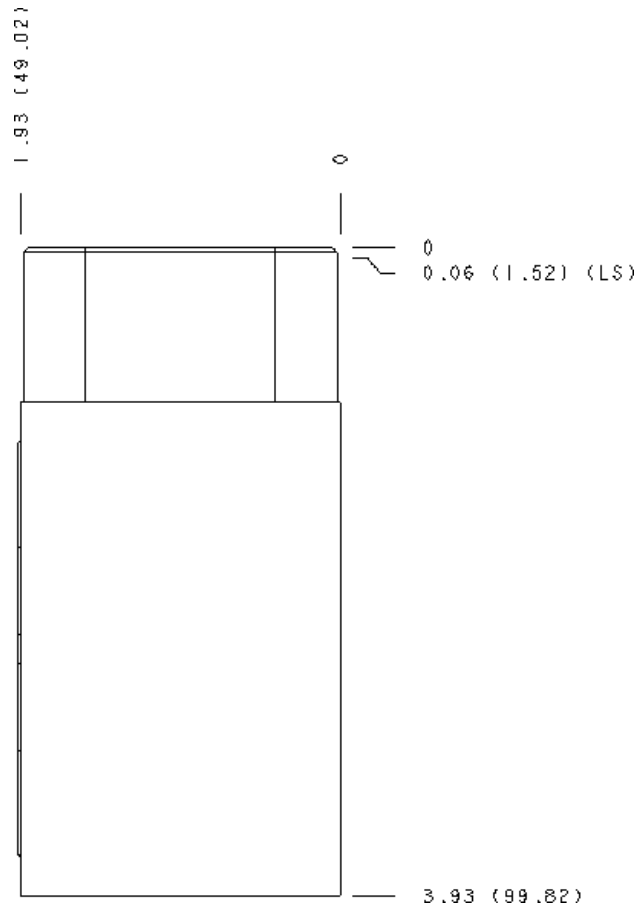

Face 10

