

MODELL
DBM

T nach A oder T nach B
EINSCHRAUBBOHRUNG: T-16A

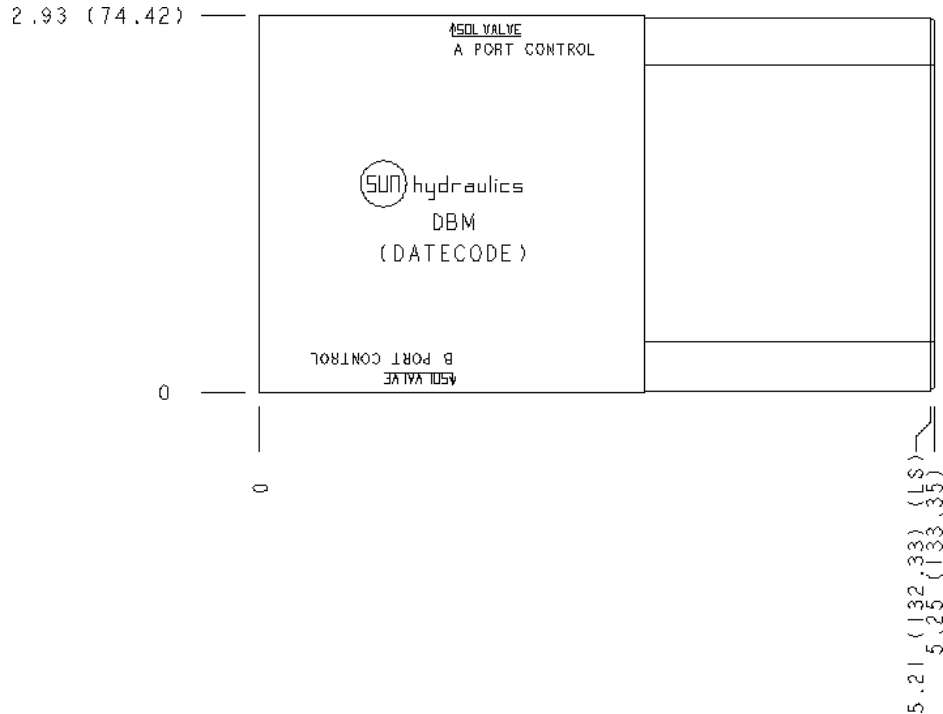
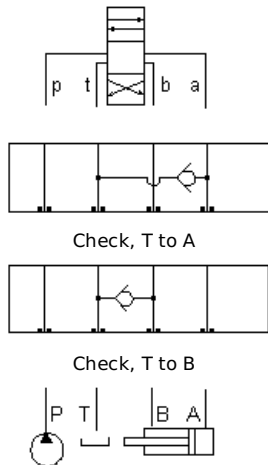

KONFIGURATION ÄNDERN

(none) Modifier 6061-T651 Aluminum, Buna-N

KOMPONENTEN

Part	Beschreibung	Anzahl
500-001-014	O-Ring	5
700-001	Seal Plate	1

BEMERKUNGEN

Important: Carefully consider the maximum system pressure. The pressure rating of the manifold is dependent on the manifold material, with the port type/size a secondary consideration. Manifolds constructed of aluminum are not rated for pressures higher than 3000 psi (210 bar), regardless of the port type/size specified.

TECHNISCHE DATEN

Gehäusotyp	Sandwich
Lochbild	ISO 05
Gehäuseeigenschaften	T nach A oder T nach B
Verkettungshöhe	76 mm
Einschraubbohrung	T-16A
Open Cavities	1

SYMBOLS



CONFIGURATION OPTIONS

MODIFIER

Standard Options	/S	6061-T651 Aluminum, Buna-N
	/V	65-45-12 Ductile Iron, Buna-N, Blackened
	/N	6061-T651 Aluminum, Viton

MANIFOLD FACES

FACE GRID

1	2	3	4
5	6	7	8
9	10	11	12

Face 2

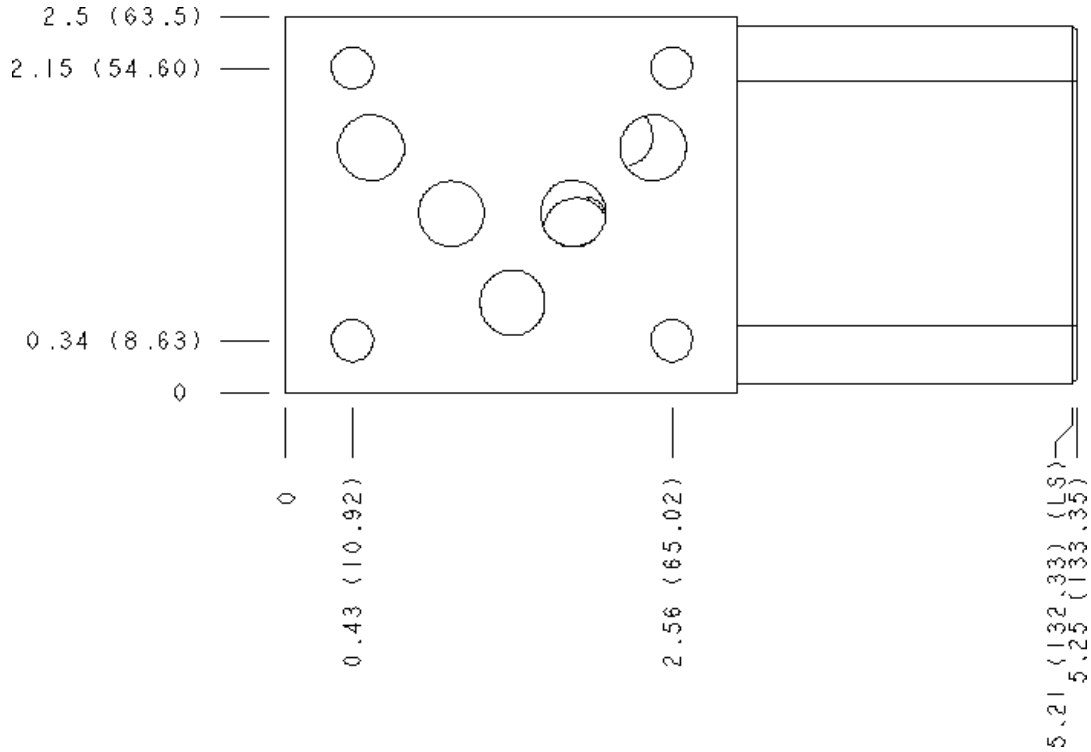

Face 6

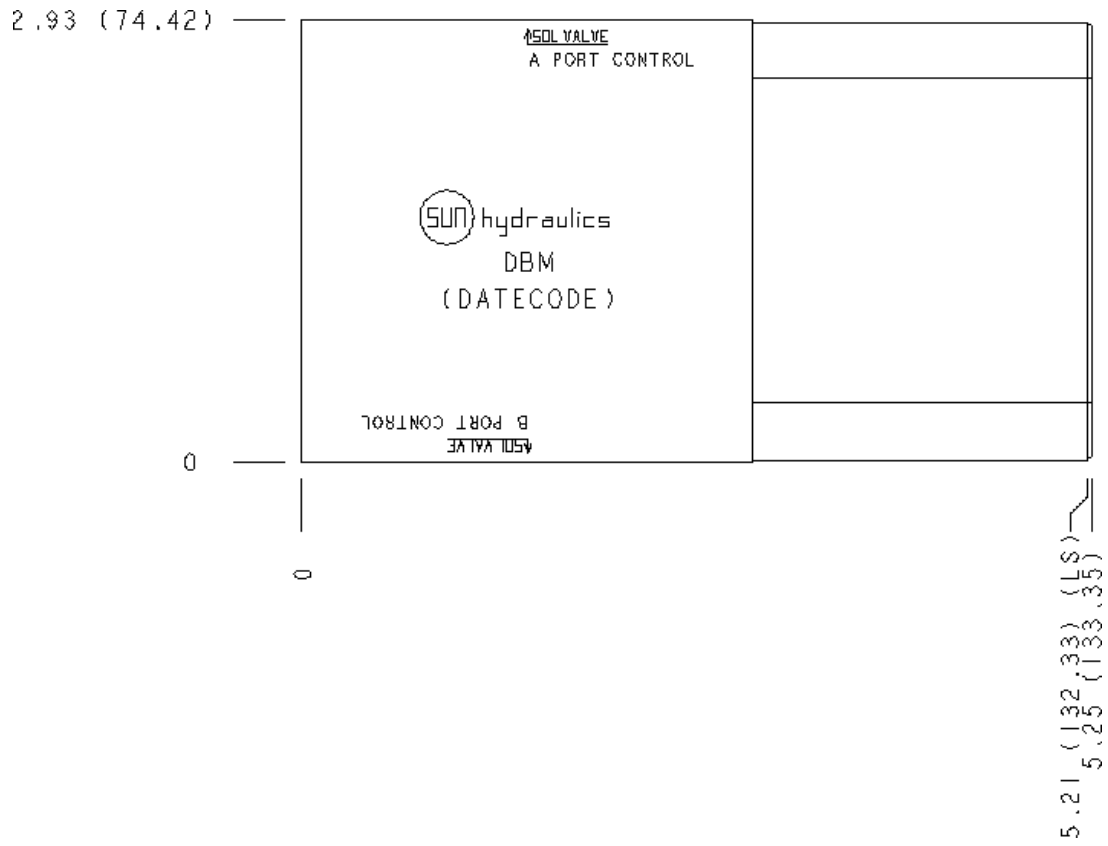

Face 7

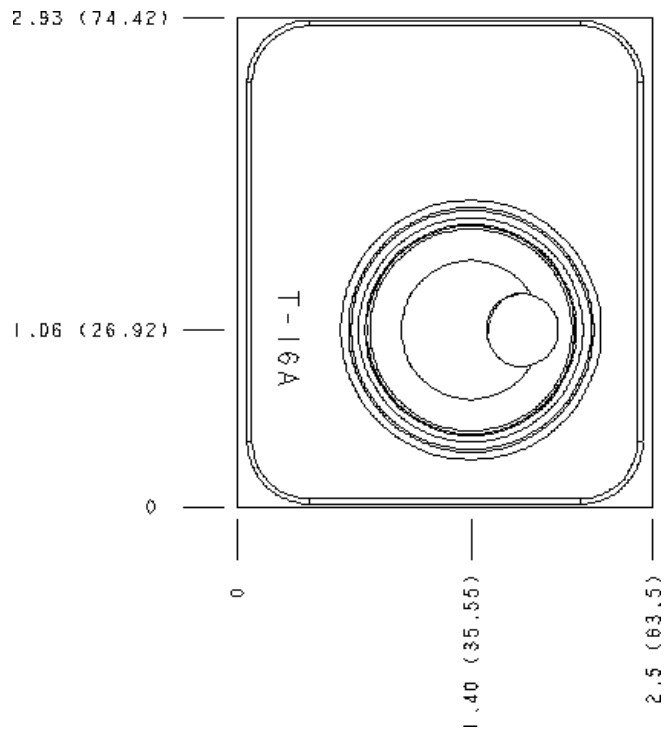

Face 10

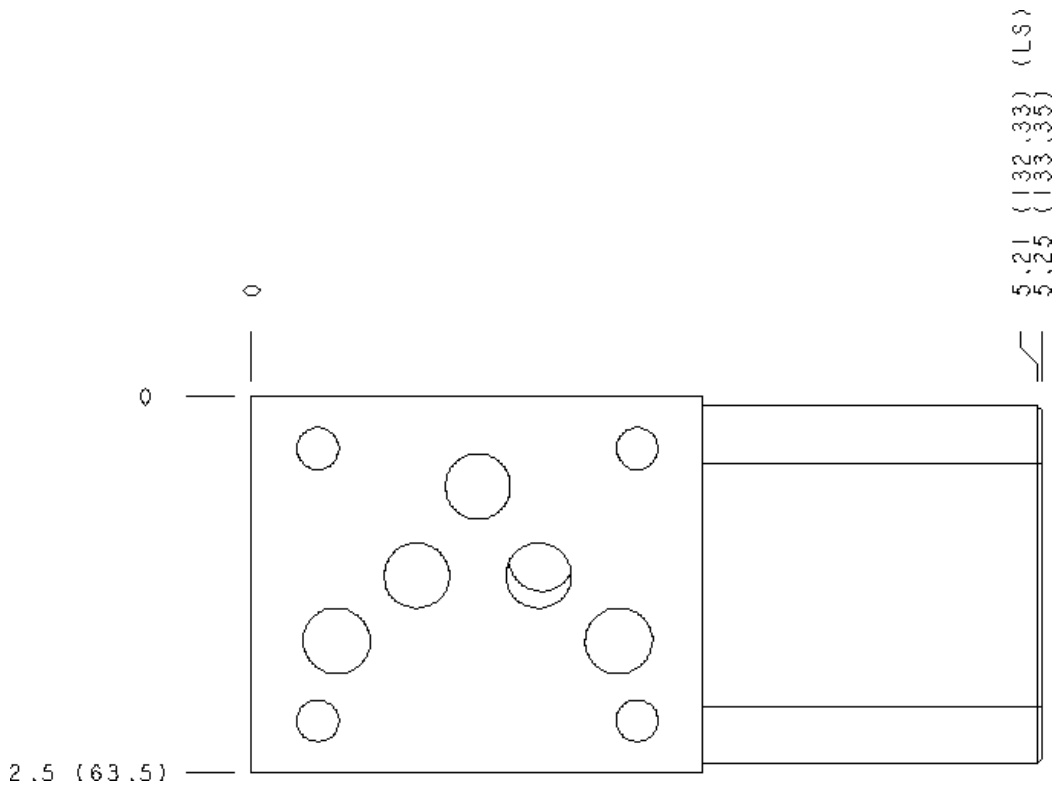

Copyright © 2002-2014 Sun Hydraulics Corporation. All rights reserved.