

MODELL
AEU

Durchgangsanschluss 1 mit Messanschluss
EINSCHRAUBBOHRUNG: T-162A

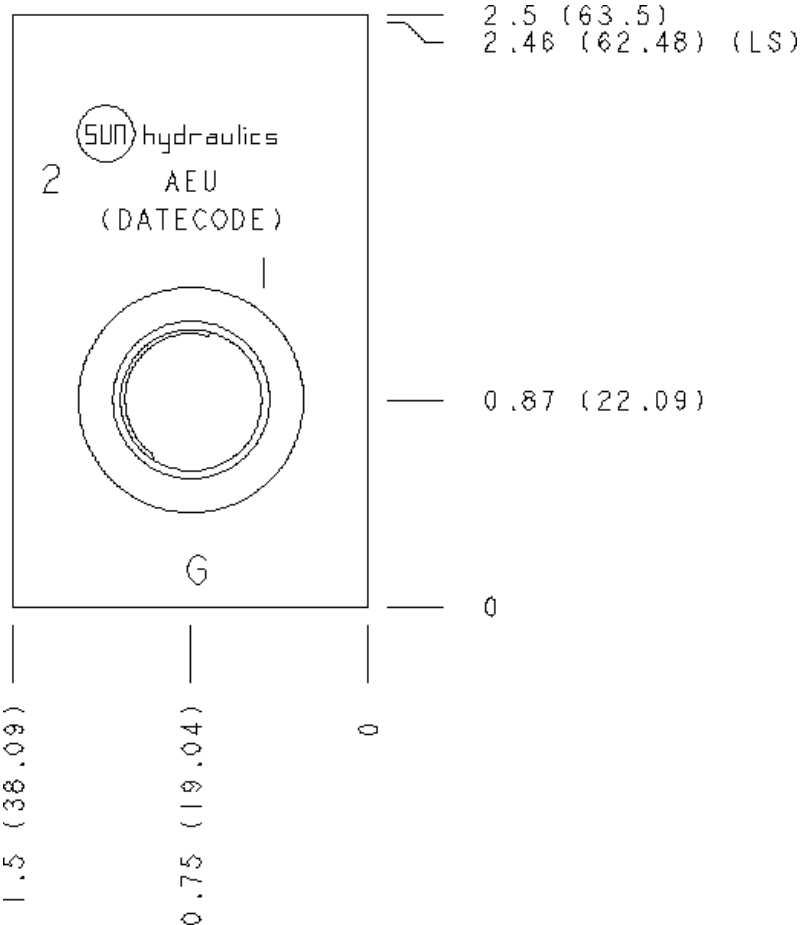
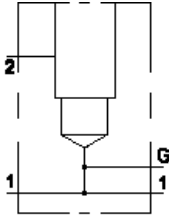

KONFIGURATION ÄNDERN

(none) Modifier 6061-T651
Aluminum, Buna-N

PORT HEADINGS AND SIZES

| Model | Port Heading | Size |
|-------|--------------|-----------|
| AEU | Ports 1 & 2 | 3/8" BSPP |
| AEU | Gage Port | 1/4" BSPP |

BEMERKUNGEN

Important: Carefully consider the maximum system pressure. The pressure rating of the manifold is dependent on the manifold material, with the port type/size a secondary consideration. Manifolds constructed of aluminum are not rated for pressures higher than 3000 psi (210 bar), regardless of the port type/size specified.

TECHNISCHE DATEN

| | |
|-----------------------------|-----------------------------------------|
| Gehäusetyp | Rohrleitungseinbau |
| Lochbild | Kein |
| Gehäuseeigenschaften | Durchgangsanschluss 1 mit Messanschluss |
| Gewinde der Montagebohrung | M6 x 1.0-6H |
| Montagebohrungstiefe | 12,7 mm |
| Anzahl der Montagebohrungen | 2 |
| Einschraubbohrung | T-162A |
| Open Cavities | 1 |
| Anschlussgröße | G 3/8" |

CONFIGURATION OPTIONS

MODIFIER

Standard Options

6061-T651 Aluminum, Buna-N

MANIFOLD FACES

FACE GRID

| | | | |
|---|----|----|----|
| 1 | 2 | 3 | 4 |
| 5 | 6 | 7 | 8 |
| 9 | 10 | 11 | 12 |

Face 2

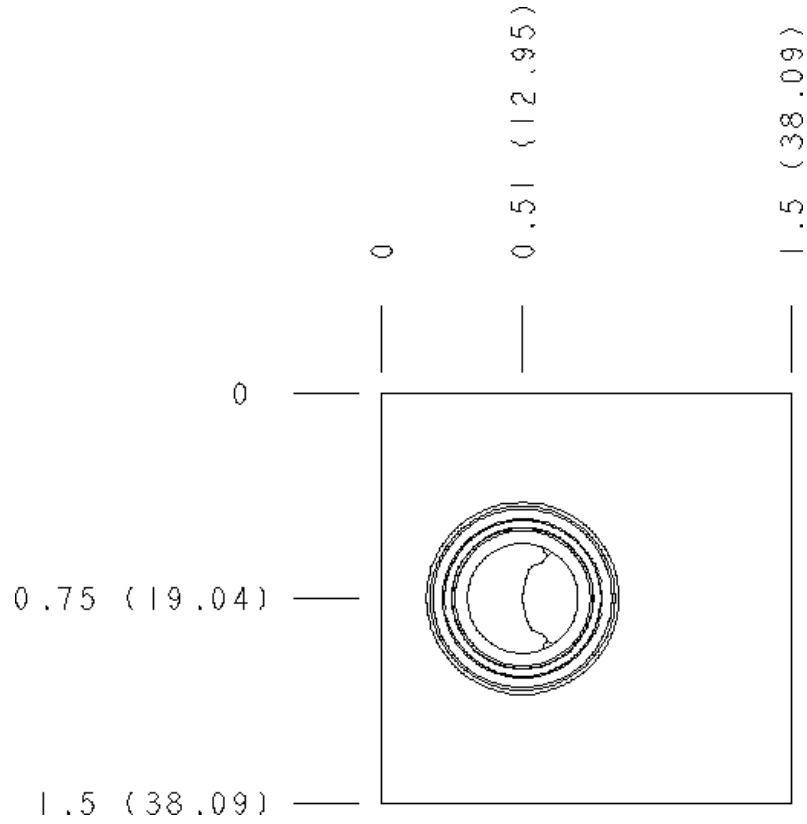

Face 5

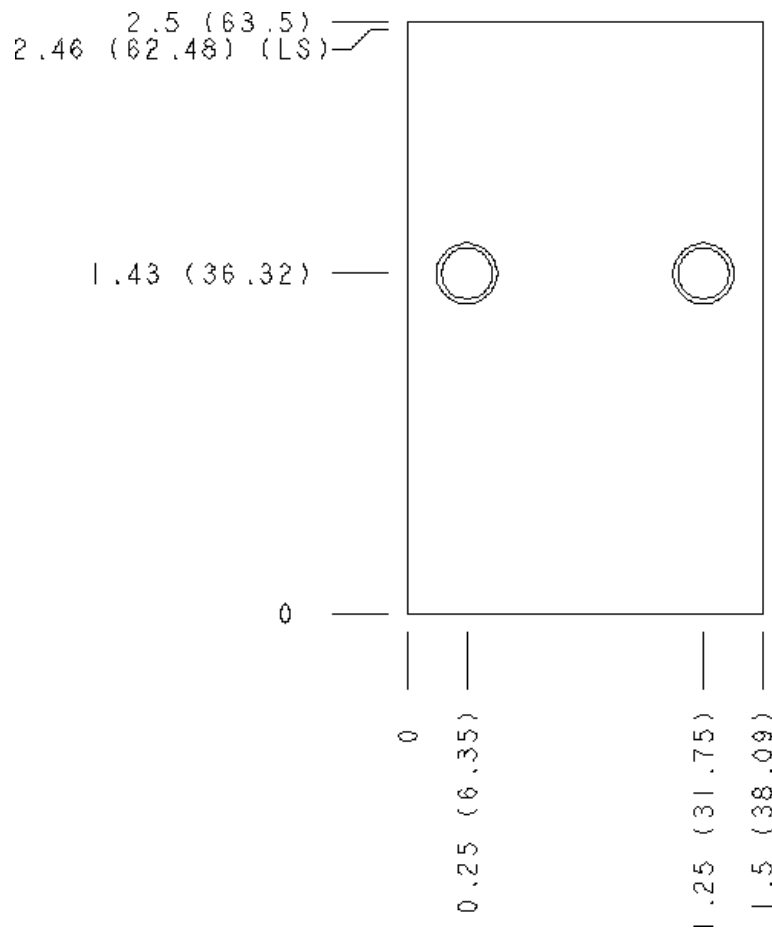

Face 6

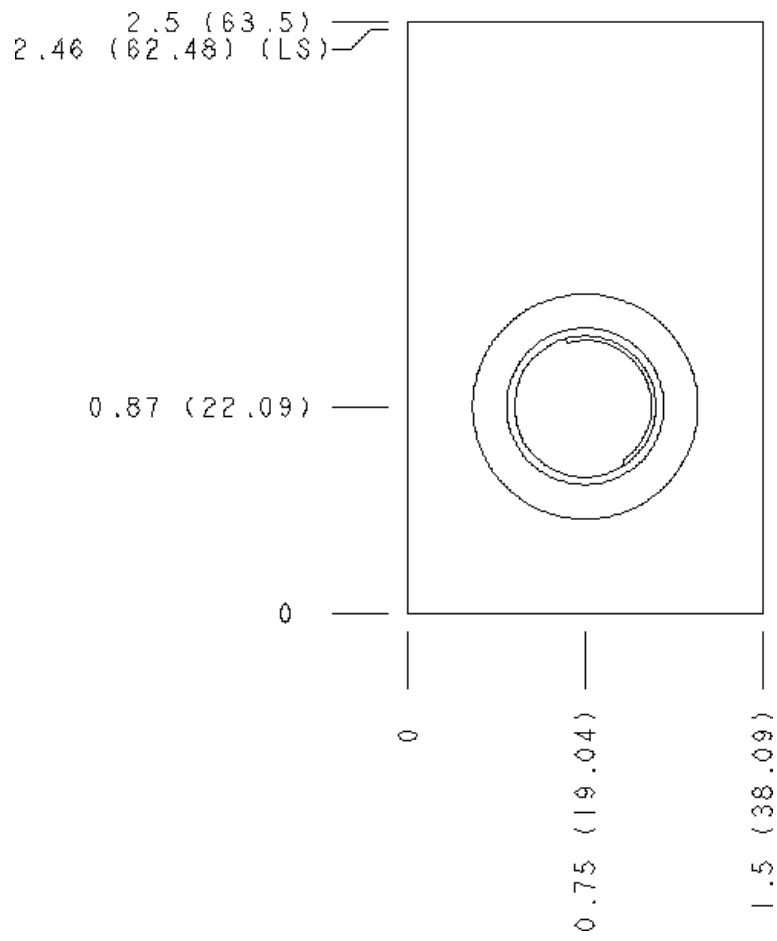

Face 7

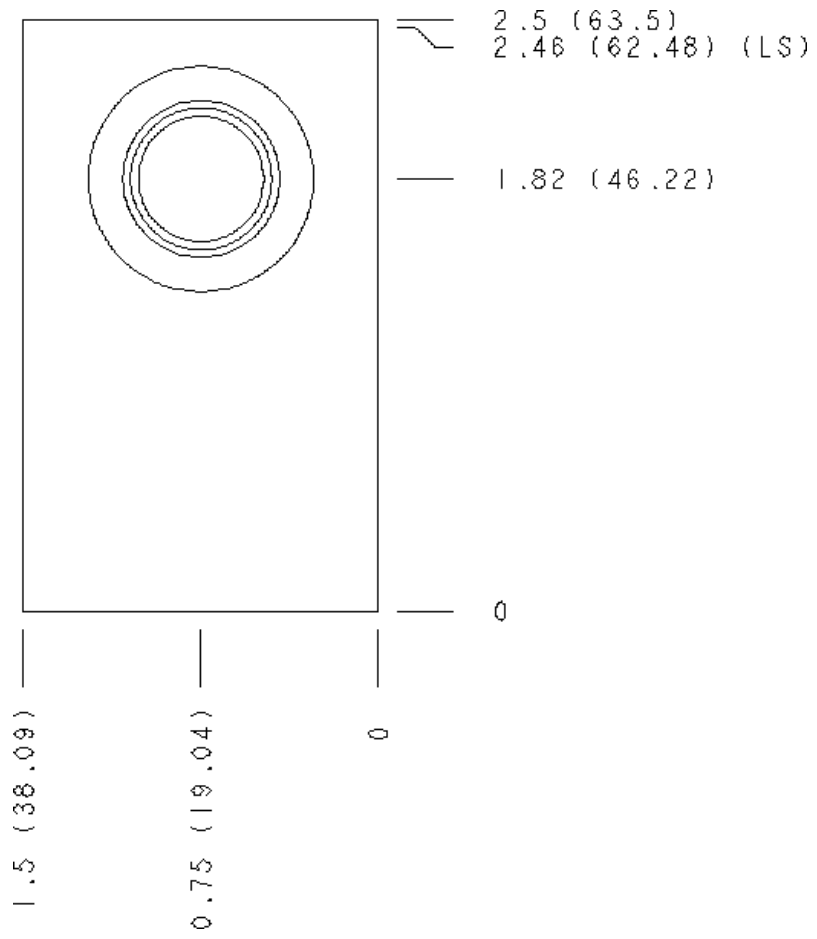

Face 8

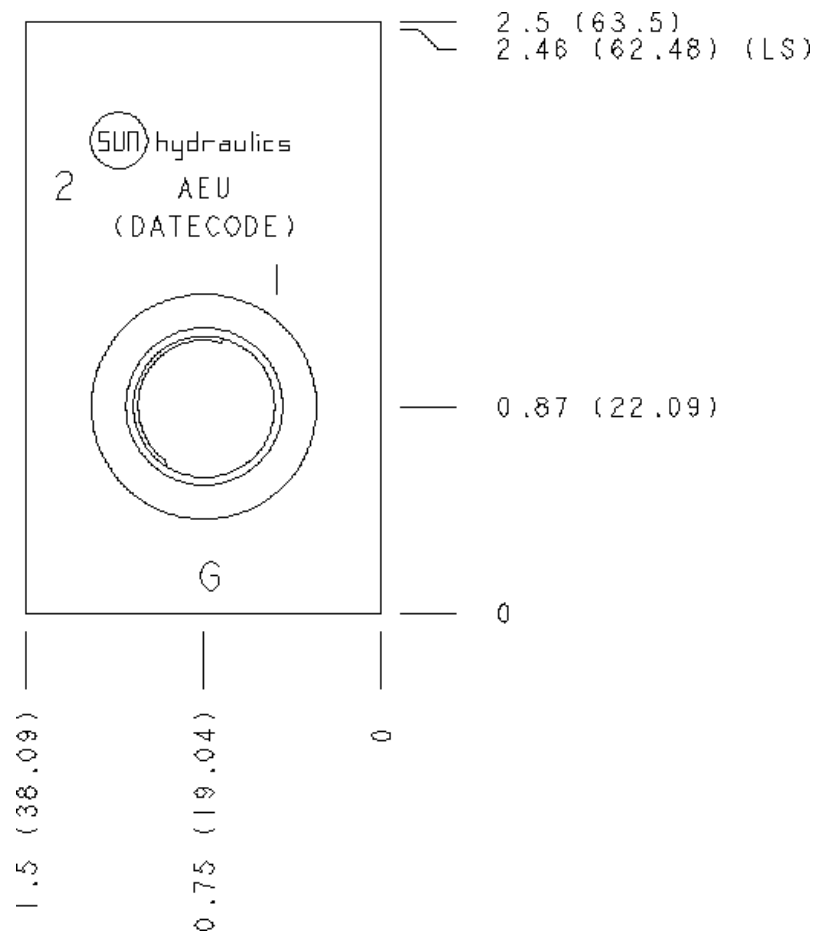

Face 10

