

MODELL
ACT

Gerades Verrohrungsgehäuse
EINSCHRAUBBOHRUNG: T-162A

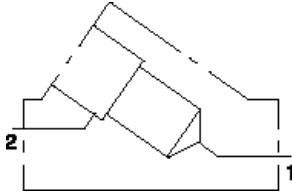

KONFIGURATION ÄNDERN

(none) Modifier 6061-T651
Aluminum, Buna-N

PORT HEADINGS AND SIZES

Model	Port Heading	Size
ACT	All Ports	1/4" BSPP

BEMERKUNGEN

Important: Carefully consider the maximum system pressure. The pressure rating of the manifold is dependent on the manifold material, with the port type/size a secondary consideration. Manifolds constructed of aluminum are not rated for pressures higher than 3000 psi (210 bar), regardless of the port type/size specified.

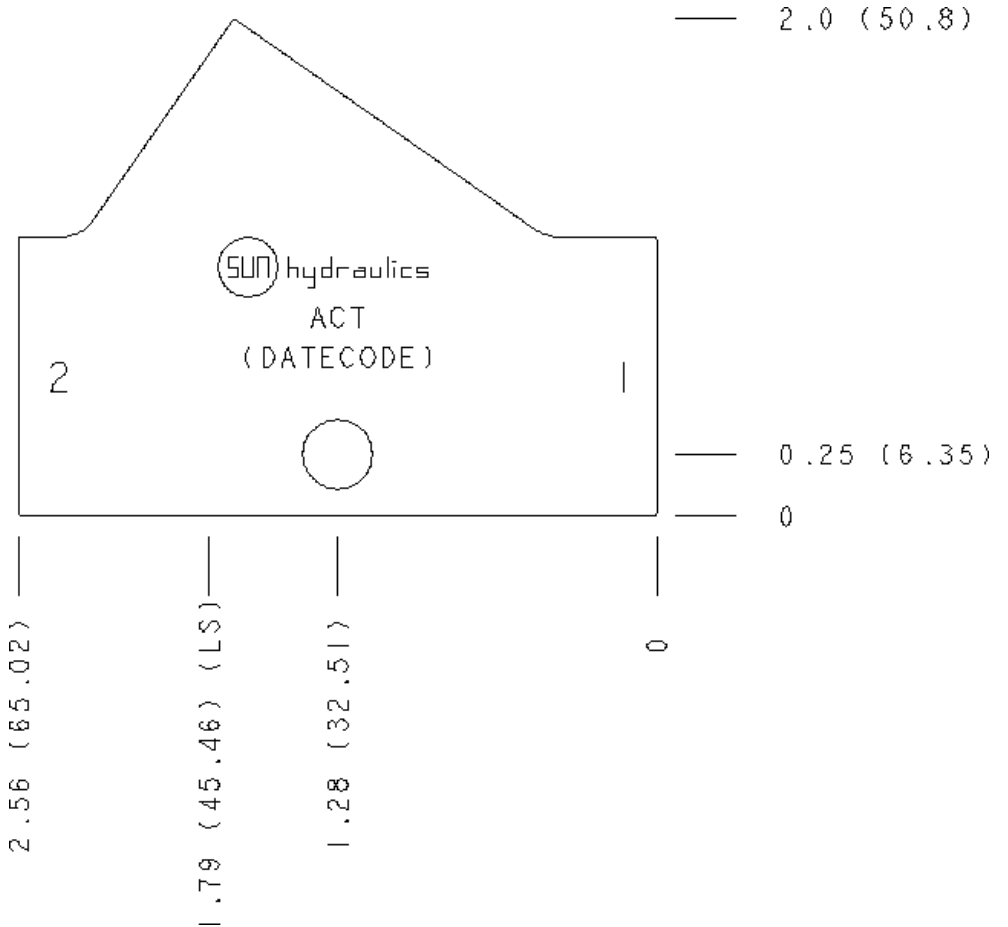

TECHNISCHE DATEN

Gehäusotyp	Rohrleitungseinbau
Lochbild	Kein
Gehäuseeigenschaften	Gerades Verrohrungsgehäuse
Montagebohrungsdurchmesser	7,1 mm
Montagebohrungstiefe	durchgehend
Anzahl der Montagebohrungen	1
Einschraubbohrung	T-162A
Open Cavities	1
Anschlussgröße	G 1/4"

CONFIGURATION OPTIONS

MODIFIER

Standard Options

6061-T651 Aluminum, Buna-N

MANIFOLD FACES

FACE GRID

1	2	3	4
5	6	7	8
9	10	11	12

Face 2

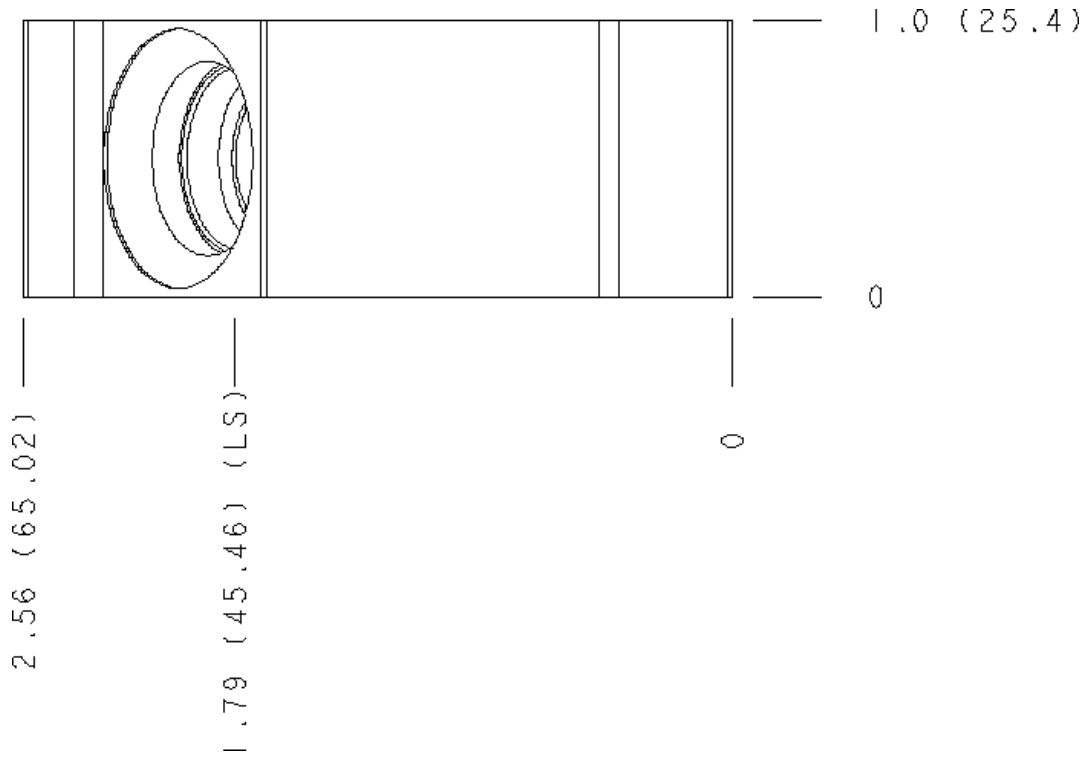

Face 5

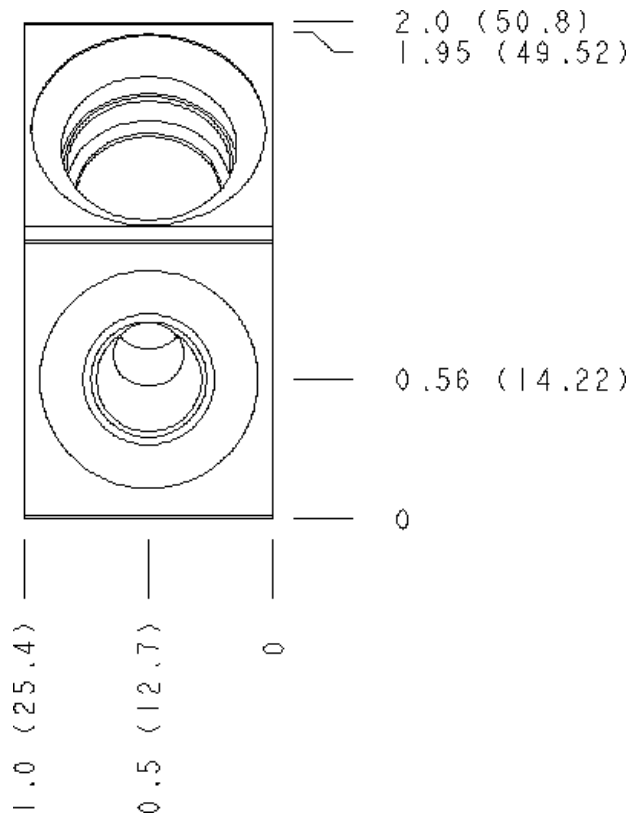

Face 6

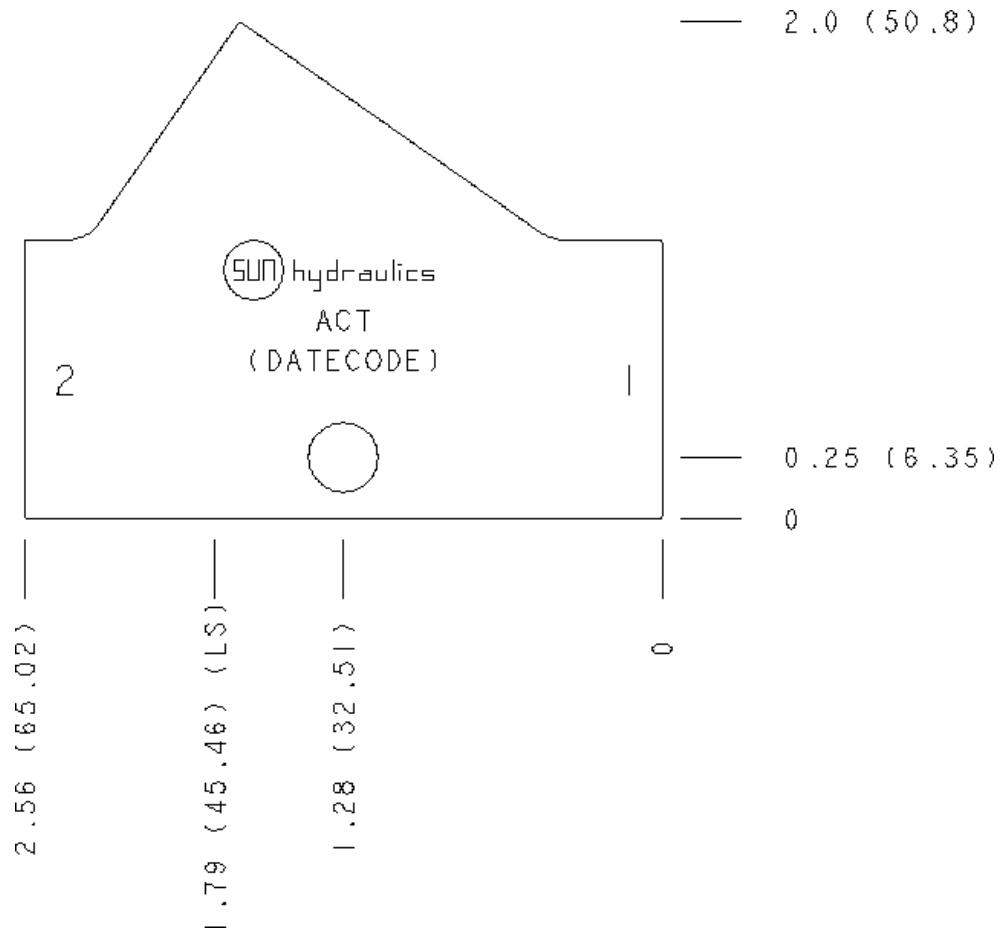

Face 7

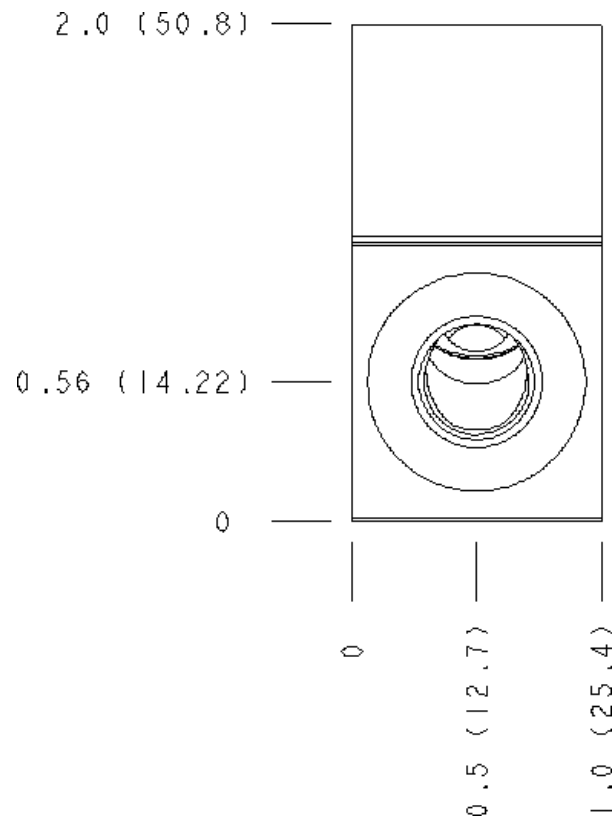

Copyright © 2002-2014 Sun Hydraulics Corporation. All rights reserved.